

Intel® RAID SSD Cache 2.0

with LSI MegaRAID* CacheCade* Pro 2.0 Read/Write Caching Technology

Read and Write Caching Premium Feature Key for Intel® RAID SAS-2 ROC-based Controller Cards

KEY BENEFITS

Accelerates performance of existing HDD arrays with small upfront investment

Read and Write caching of hot spot data for significant reduction in I/O latency

Optimized for real-world workloads of transaction-intensive applications

Simple, intuitive management tools to assign and manage SSD Cache pool

Reduce Latency Bottlenecks for Server-based HDD Volumes

Today's workload-intensive business applications are often constrained by the performance limitations of their existing hard disk drives (HDDs). With this type of storage infrastructure already in place, many businesses have not previously been able to adopt higher performing solid state drives (SSDs) as a full array of SSD's is too costly despite the significant IOPs benefit.

Now, it is possible to accelerate the performance of existing HDD arrays without making substantial investments in new hardware by deploying SSD Cache with LSI MegaRAID CacheCade technology. SSD Cache leverages SSDs in front of HDD volumes to create high-capacity, high-performance controller cache pools.

Intel® RAID SSD Cache 2.0 with LSI MegaRAID CacheCade Pro 2.0 read/write caching technology eliminates the need for manually configured hybrid arrays by intelligently and dynamically managing frequently-accessed data and copying it from hard disk drive (HDD) volumes to a higher performance layer of SSD cache (see figure 1). Copying the most accessed data ('hot spot') to flash cache relieves the primary HDD array from time-consuming transactions which allows for more efficient hard disk operation, reduced latency, and accelerated read and write speeds. This provides significant improvements to overall system performance - two to twelve times that of HDD-only configurations - for a wide variety of server applications including web, file, online transaction processing (OLTP) database, data mining and other transaction-intensive applications.

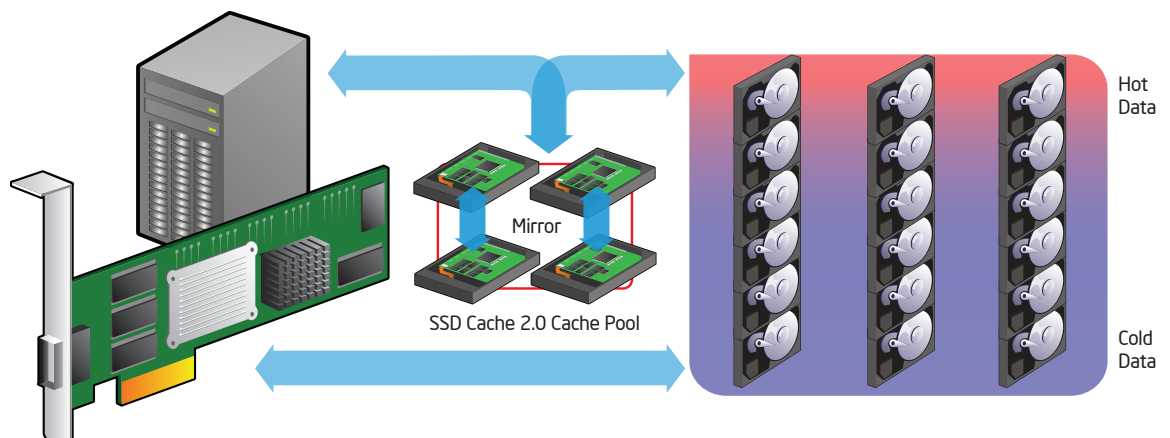

Figure 1: SSD Cache 2.0 intelligently copies hot data to low latency, redundant SSD cache.

Cost Effective Application Acceleration

Intel® RAID SSD Cache 2.0 offers the perfect combination of HDD capacity and SSD speed. The integrated CacheCade Pro 2.0 technology is designed to improve the performance of a server's existing drive volume(s) by, dynamically utilizing SSDs as a dedicated pool of RAID controller cache to maximize random read and write performance.

SSD Cache 2.0 allows for taking advantage of SSD without manual storage management and in-house application tuning costs, of full arrays of SSD. This lowers the total cost of storage ownership for datacenters and small-to-medium businesses.

Application Acceleration Across Business Critical Workloads

Intel® RAID SSD Cache with CacheCade Pro 2.0 technology is the industry's first software solution that offers both read and write controller-based caching on SSDs, dramatically enhancing the performance gains achieved by the previous generation CacheCade software. With the addition of write caching support, read/write-intensive workloads such as Exchange server, high performance computing (HPC) applications, Web 2.0 and other IO-intensive online transaction processing (OLTP) database system workloads, experience dramatic performance improvements.

SSD Cache Makes Applications Faster

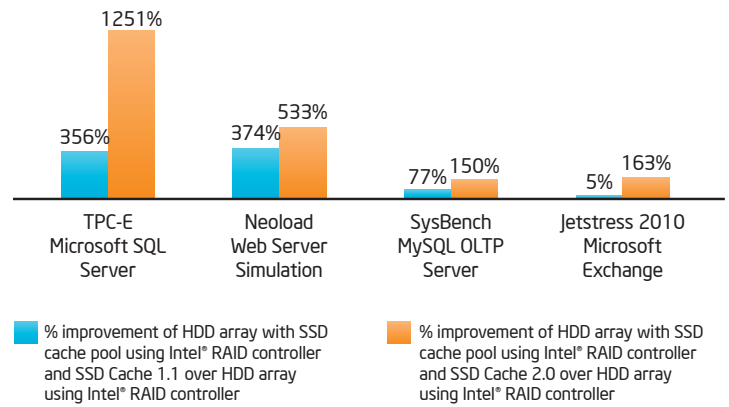

Intel® RAID SSD Cache 2.0 with MegaRAID CacheCade Pro 2.0 Technology

Physical Key Order Code	AXXRPFKSSD for RS2 series ROC-based (LSI2108) products AXXRPFKSSD2 for RS25 series ROC-based (LSI2208) products
Operating Systems	All operating systems supported by specific Intel RAID controller card
Supported SSDs	Please visit the specific RAID product page on www.intel.com for a complete list of tested SSDs
Max number of SSDs in a CacheCade SSD pool	32
Max number of SSC VD supported per controller	Up to 64 (The total # of HDD VDs plus SSD Cache VDs must not exceed 64)
Max CacheCade capacity per controller	512GB

For more information on Intel® RAID SSD Cache 2.0, visit: www.intel.com/go/RAID

For more information on how to make the Intel® RAID SSD Cache 2.0 part of your server environment, please contact an Intel® Channel Partner Program participant.

PERFORMANCE TESTS AND RATINGS ARE MEASURED USING SPECIFIC COMPUTER SYSTEMS AND/OR COMPONENTS AND REFLECT THE APPROXIMATE PERFORMANCE OF INTEL PRODUCTS AS MEASURED BY THOSE TESTS. ANY DIFFERENCE IN SYSTEM HARDWARE OR SOFTWARE DESIGN OR CONFIGURATION MAY AFFECT ACTUAL PERFORMANCE. BUYERS SHOULD CONSULT OTHER SOURCES OF INFORMATION TO EVALUATE THE PERFORMANCE OF SYSTEMS OR COMPONENTS THEY ARE CONSIDERING PURCHASING. FOR MORE INFORMATION ON PERFORMANCE TESTS AND ON THE PERFORMANCE OF INTEL PRODUCTS, VISIT [HTTP://WWW.INTEL.COM/PERFORMANCE/RESOURCES/LIMITS.HTM](http://www.intel.com/performance/resources/limits.htm) OR CALL (U.S.) 1-800-628-8686 OR 1-916-356-3104.

INFORMATION IN THIS DOCUMENT IS PROVIDED IN CONNECTION WITH INTEL® PRODUCTS. NO LICENSE, EXPRESS OR IMPLIED, BY ESTOPPEL OR OTHERWISE, TO ANY INTELLECTUAL PROPERTY RIGHTS IS GRANTED BY THIS DOCUMENT. EXCEPT AS PROVIDED IN INTEL'S TERMS AND CONDITIONS OF SALE FOR SUCH PRODUCTS, INTEL ASSUMES NO LIABILITY WHATSOEVER, AND INTEL DISCLAIMS ANY EXPRESS OR IMPLIED WARRANTY, RELATING TO SALE AND/OR USE OF INTEL PRODUCTS INCLUDING LIABILITY OR WARRANTIES RELATING TO FITNESS FOR A PARTICULAR PURPOSE, MERCHANTABILITY, OR INFRINGEMENT OF ANY PATENT, COPYRIGHT OR OTHER INTELLECTUAL PROPERTY RIGHT. UNLESS OTHERWISE AGREED IN WRITING BY INTEL, THE INTEL PRODUCTS ARE NOT DESIGNED NOR INTENDED FOR ANY APPLICATION IN WHICH THE FAILURE OF THE INTEL PRODUCT COULD CREATE A SITUATION WHERE PERSONAL INJURY OR DEATH MAY OCCUR. Intel products are not intended for use in medical, life-saving, or life-sustaining applications. Intel may make changes to specifications and product descriptions at any time, without notice.

All products, dates, and figures specified are preliminary based on current expectations, and are subject to change without notice. Availability in different channels may vary.

Intel, the Intel logo, Intel. Leap ahead, and the Intel. Leap ahead logo are trademarks of Intel Corporation in the U.S. and other countries.

Copyright © 2011 Intel Corporation. All rights reserved. Intel, the Intel logo, and Xeon are trademarks of Intel Corporation in the U.S. and other countries.

*Other names and brands may be claimed as the property of others.

Printed in USA

07/09/SJ/PDF

Please Recycle

325932-001US

