



Intel® RAID: Get The Most Out of Your Xeon® Processor-based System

November 30, 2011



Agenda

- Why Intel RAID?
- Portfolio Overview & Product Highlights
- New Backup Technology
- RAID Software
- SSD Cache 2.0
- Romley RAID Preview



Legal Disclaimer

INFORMATION IN THIS DOCUMENT IS PROVIDED IN CONNECTION WITH INTEL® PRODUCTS. NO LICENSE, EXPRESS OR IMPLIED, BY ESTOPPEL OR OTHERWISE, TO ANY INTELLECTUAL PROPERTY RIGHTS IS GRANTED BY THIS DOCUMENT. EXCEPT AS PROVIDED IN INTEL'S TERMS AND CONDITIONS OF SALE FOR SUCH PRODUCTS, INTEL ASSUMES NO LIABILITY WHATSOEVER, AND INTEL DISCLAIMS ANY EXPRESS OR IMPLIED WARRANTY, RELATING TO SALE AND/OR USE OF INTEL® PRODUCTS INCLUDING LIABILITY OR WARRANTIES RELATING TO FITNESS FOR A PARTICULAR PURPOSE, MERCHANTABILITY, OR INFRINGEMENT OF ANY PATENT, COPYRIGHT OR OTHER INTELLECTUAL PROPERTY RIGHT. INTEL PRODUCTS ARE NOT INTENDED FOR USE IN MEDICAL, LIFE SAVING, OR LIFE SUSTAINING APPLICATIONS.

All products, computer systems, dates, and figures specified are preliminary based on current expectations, and are subject to change without notice. Intel may make changes to specifications and product descriptions at any time, without notice.

Performance tests and ratings are measured using specific computer systems and/or components and reflect the approximate performance of Intel products as measured by those tests. Any difference in system hardware or software design or configuration may affect actual performance. Buyers should consult other sources of information to evaluate the performance of systems or components they are considering purchasing. For more information on performance tests and on the performance of Intel products, visit [Intel Performance Benchmark Limitations](#)

Intel does not control or audit the design or implementation of third party benchmarks or Web sites referenced in this document. Intel encourages all of its customers to visit the referenced Web sites or others where similar performance benchmarks are reported and confirm whether the referenced benchmarks are accurate and reflect performance of systems available for purchase.

Intel processor numbers are not a measure of performance. Processor numbers differentiate features within each processor family, not across different processor families. See www.intel.com/products/processor_number for details.

Intel, processors, chipsets, and desktop boards may contain design defects or errors known as errata, which may cause the product to deviate from published specifications. Current characterized errata are available on request.

Intel Virtualization Technology requires a computer system with a processor, chipset, BIOS, virtual machine monitor (VMM) and applications enabled for virtualization technology. Functionality, performance or other virtualization technology benefits will vary depending on hardware and software configurations. Virtualization technology-enabled BIOS and VMM applications are currently in development.

64-bit computing on Intel architecture requires a computer system with a processor, chipset, BIOS, operating system, device drivers and applications enabled for Intel® 64 architecture. Performance will vary depending on your hardware and software configurations. Consult with your system vendor for more information.

Intel, Intel Xeon, Intel Core microarchitecture, and the Intel logo are trademarks or registered trademarks of Intel Corporation or its subsidiaries in the United States and other countries.



Why Intel® RAID?



Broad Portfolio

- SW RAID, standard add-in cards, and unique ROC/IOC-based system boards allow for tailored solutions from entry-level to scalable performance



Ease of deployment

- RAID solutions fully validated across Intel server product line and aligned with platform lifecycles
- New intuitive web-based interface supporting all products and allows for easy set-up without time-consuming learning curves



World class performance and features



















- Leading technology such as SAS 2.0, DDR3, LSI MegaRAID* and FastPath* I/O allow for delivering exceptional performance and additional benefits such as SSD Optimizations and Self-Encrypting Drive support



Intel one-stop shopping, training, and support

- Intel RAID is backed by Intel's channel programs and a team of RAID experts that are available to assist you with design wins
- Lower total cost of ownership

Intel® RAID Controllers – SAS 2.0 w/ 6Gbps Standard Add-In Cards

Scalable Performance	  <p>RS25NB008 8 port external with dual core ROC and 1 GB DDR3</p>	 <p>RS2SG244 Up to 24 drives direct or 240 with expanders</p>	
	 <p>RS2PI008 8 port external</p>	 <p>RS2WG160 16 ports internal</p>	
		 <p>RES2SV240 24 Port Expander Card Ports can be in or out. Low Profile allows use in 2U without risers</p>	
Mainstream	 <p>RS2BL040/VB080 4 Internal ports. VB model includes Maintenance Free Backup</p> 	 <p>RS2MB044 4 Internal and 4 External</p>  <p>RS25DB080 8 port internal with dual core ROC and 1 GB DDR3</p>   <p>RS2BL080/VB080 8 port internal</p>   <p>RT3WB080 8 port internal for SATA drives</p>	
Entry	 <p>RS2WC040 Entry HW RAID 0/1/10/5</p>	  <p>RS25GB008 External JBOD Connectivity</p>  <p>RS2WC080 Entry HW RAID 0/1/10/5</p>	
	4 Port	8 Port	16+ Port

Intel® Integrated RAID

Unique system boards with SAS & RAID functionality

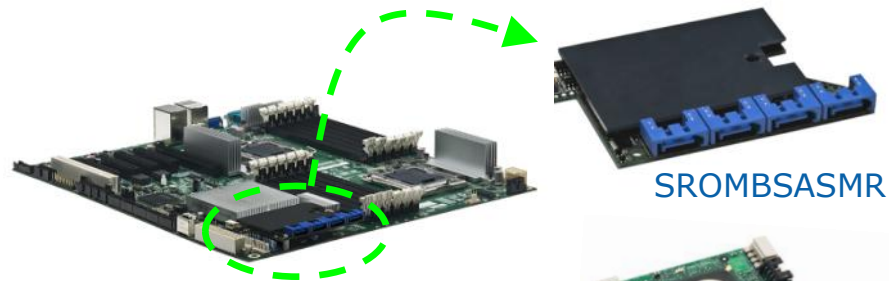
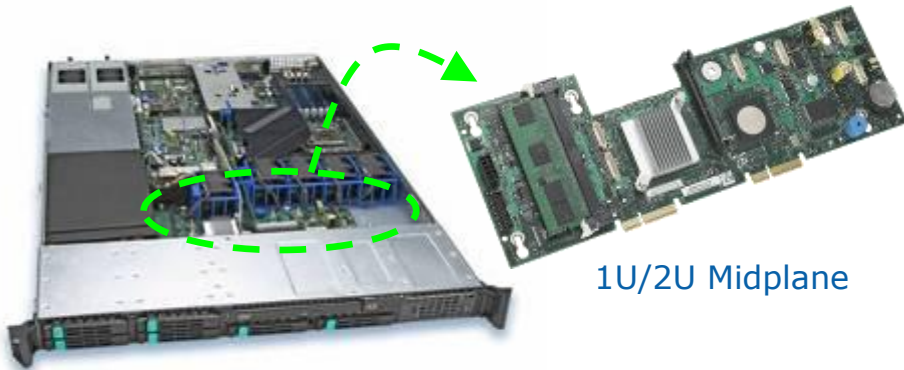

SAS-2.0 Modules



RMS2MH080
"Mountain Home"
6G SAS ROC Module
RAID 0,1,5,6, 10,
50, 60



RMS2AF080/040
"American Falls"
6G SAS IOC Entry-RAID
0,1,5,10,50



RMS2LL080/040
"Lake Louise"
6G SAS IOC Entry-
RAID 0,1,1E

Value above a standard add-in card



Intel® RAID Controller RS25DB080

"Delray Beach"

KEY FEATURES:

- Dual-core ROC
- 1GB DDR3 cache
- 8 internal ports
- Full Intelligent RAID 0,1,5,6 and spans (10, 50, 60)

KEY BENEFITS:

- 11% max read throughput increase
- 33% max write throughput increase
- 3 x IOPs
- Early customer feedback that performance delta on real world applications is even higher!

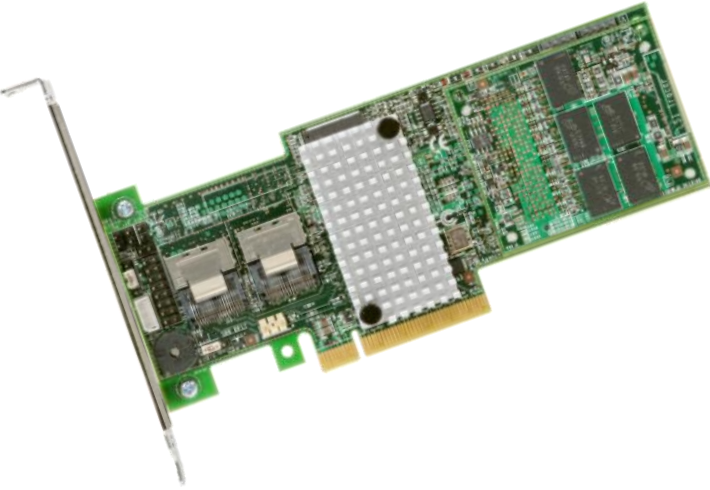

World's fastest RAID Controller!

Intel® RAID 5 Read Performance

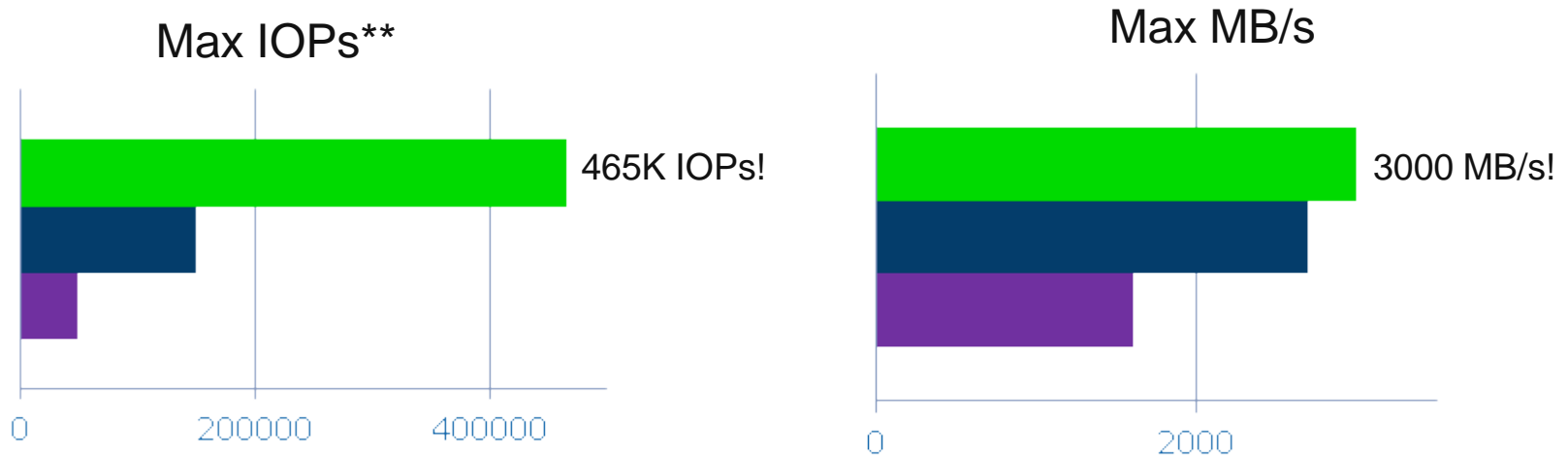

** Max IOPS requires optional SSD Cache with FastPath I/O upgrade key

- = Intel RAID Controller RS25DB080 (2nd Gen SAS-2)
- = Intel RAID Controller RS2BL080 (SAS-2)
- = Intel RAID Controller SRCSASJV (SAS-1)

Industry leading performance!

Performance tests and ratings are measured using specific computer systems and/or components and reflect the approximate performance of Intel products as measured by those tests. Any difference in system hardware or software design or configuration may affect actual performance. Buyers should consult other sources of information to evaluate the performance of systems or components they are considering purchasing. For more information on performance tests and on the performance of Intel products, visit <http://www.intel.com/performance/resources/limits.htm> or call (U.S.) 1-800-628-8686 or 1-916-356-3104.

* Other names and brands may be claimed as the property of others.



Intel® RAID Expander RES2SV240

"Scotch Valley"



KEY FEATURES:

- 24 total ports (multiples of 4 can be in or out)
- PCIe x4 power; or 4 pin cabled power
- LSI SAS 2.0/6Gb Expander
- LP (low profile) for use in 2U chassis

KEY BENEFITS:

- Inexpensive option for 12 to 20 drive solutions (save up to ½ price on solution vs. high port RAID card)
- System design flexibility – plug into PCIe or mount on chassis wall
- Team with RS25DB080 to get industry leading >8 port performance

Exceptional alternative for >8 drive solutions!

Intel® RAID Module RMS2AF080/040 "American Falls"

KEY FEATURES:

- 1U capable
- Common firmware with Mainstream HW RAID cards
- RAID 1 performed onboard (true HW RAID)
- Hybrid RAID 5 performed in firmware uses Xeon and 128MB of board memory for parity calculations

KEY BENEFITS:

- System design flexibility; Preserves PCIe slot
- Easy to use management utilities included
- Excellent performance
- Low-cost alternative (~1/2 price of Mainstream)

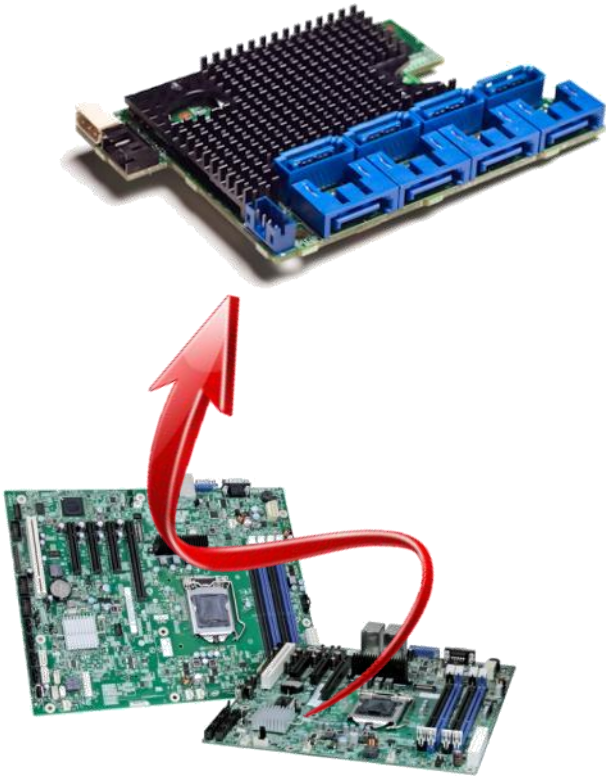

Team w/ Server Board S1200BT for perfect entry-level solution!



Intel RAID Write Cache Settings

1. Write Back:

- Write operations complete when cache receives data
- Better performance/higher risk
- Cache backup solution recommended

2. Write Through:

- Write operations complete when disks receives data
- Better data protection with no battery present

3. Forced Write Back:

- Select this mode to use Write Back mode with no BBU or a bad BBU

Also note that data is buffered in controller memory in order to perform parity calculations

New Long Life, Higher Temp Lithium Polymer BBU

BBU8 and BBU9	Mode 1	Mode 2	Mode 3	Mode 4	Mode 5		Compare to BBU7
Data Retention Time (DRT)	12 Hrs	12 Hrs	24 Hrs	48 Hrs	48 Hrs		48 Hrs
Transparent Learn Cycle	✓	✓	✓	✗	✗		✗
Op Temp (Charging Temp)	45°C	55°C	45°C	45°C	55°C		45°C
Remote mounting cable and bracket included	Yes	Yes	Yes	Yes	Yes		Yes
Estimated service life	5 years	3 years	3 years	3 years	1 year		1 year

BBU8 works with all Intel **RS2** products such as RS2BL080 (SAS-2 with an LSI2108 ROC & DDR2)

BBU9 works with Intel **RS25** products such as RS25DB080 (SAS-2.1 with LSI2208 ROC & DDR3)

RAID Cache Backup Options



Parameter	Standard Battery-based Design	Maintenance Free Backup
Maintenance schedule	Battery should be replaced every 1-3 years	Not required
Maintenance impact	Server must be opened (usually means taken off line and removed from rack)	No impact
Data retention time	Up to 72 hours, less if battery is degraded	10 years
Charge time	4.5 to 9 hours	Capacitor charges while the system boots
Time to cache protection	24 to 36 hours for initial capacity test	Immediate
Disposal issues	Need to safely dispose of hazardous battery material	None



Intel® RAID Controllers RS2VB080/040 includes a MFBU

MFBU = No more service calls to replace worn out batteries!



Hardware vs. Software RAID

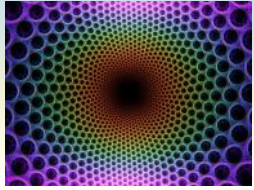

Algorithm



- Hardware RAID Algorithms are in controller firmware
- Software RAID algorithms are in the controller driver

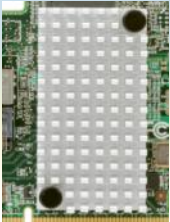

Processor



- Hardware RAID utilizes a dedicated processor
- Software RAID utilizes system CPU resources



Memory



- Hardware RAID utilizes dedicated memory. Data in memory can be backup protected.
- Software RAID utilizes system memory. Data can be lost at power or MB failure.



Features



- Hardware RAID offers superior features including Premium Feature Upgrades
- Software RAID offers basic features

Software RAID targeted at Entry-Level

Intel® RAID Software Stack Solutions



Intel® Embedded Server RAID Technology II (ESRT2)

- Embedded (Chipset) software RAID
- Based on the LSI MegaRAID* Stack
- RAID 0/1/10 and optional RAID 5 support for AHCI and SCU ports with the proper Intel® RAID C600 upgrade keys

Software RAID

Intel Hardware RAID Powered by LSI* IR RAID Technology

- Internal IOC for RAID Calculations
- No XOR (RAID 0,1,10 only)
- 2MB context memory (in the IOC)
- Entry RAID adapters and modules
- No battery option

Intel Hardware RAID Powered by LSI MegaRAID Technology

- LSI ROC with dedicated processor
- 512MB – 1GB dedicated memory
- Single and Dual Parity XOR
- Mainstream and Performance
- BBU9 and Maintenance Free Backup Options

Hardware RAID

Flexibility to service multiple target markets

Intel RAID Web Console II

New Dashboard View

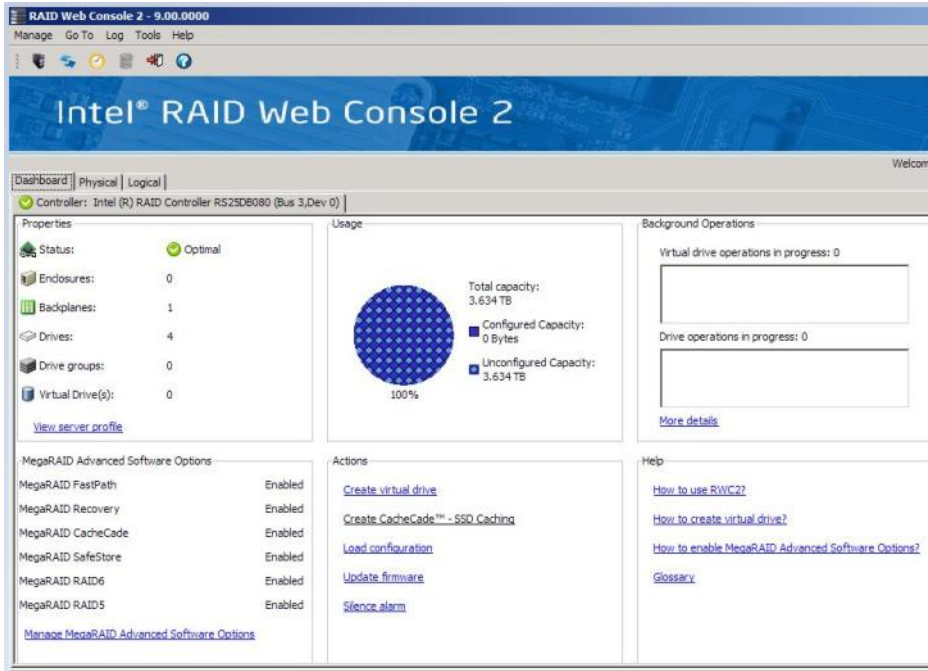

- Simplifies management of controller and RAID options
- Automatic, Manual, and Wizard Guided configuration options
- Common Java-based GUI used across all Intel RAID products

Newer Feature Highlights:

- Premium Feature support
- Improved Config Wizards
- SSD support w/ SSD Guard*
- VMware* ESXi Support
- Reversible Hot-Spare

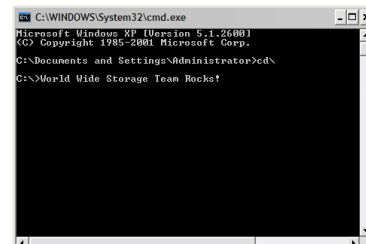
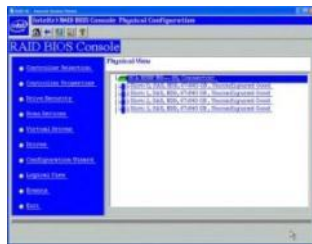

RAID Bios & Command Line Tools (shown just above) also available

Easy to use & feature rich software/user interface

Command Tool 2 Utility



- Monitor, configure, and maintain RAID Configurations.
- Script the configuration process
- Available for Windows, Linux, Solaris, FreeBSD, DOS, and EFI.
- Application and User Guide available at [\\support.intel.com](https://support.intel.com)

Example - Update Controller FW

```
CmdTool2 -AdpFwFlash -f FlashUpdt -a1
```

↓
Evoke
Command
Utility

↓
Command
for
FWFLASH

↓
File
Command

↓
File
Name

↓
Adapter
Number

RAID Configuration Utilities

Stack	OpRom	OS GUI	Command Line Interface
ESRT2	ctrl+e	RWC2 - Windows & Linux	CMDTool2 - Windows & Linux ESRT2CLI - uEFI & DOS
IR RAID	ctrl+c	RWC2 - Windows & Linux	SAS2IRCU - SAS Gen 2 - All OS CFGGen - SAS Gen 1 - All OS
MegaRAID	ctrl+g	RWC2 - Windows & Linux	CMDTool2 - All OS

Utilities Tuned to Provide the Level of Manageability Needed.

SSD Cache 2.0

1 Spinning drives provide high capacity, but low performance

3 SSD's assigned as RAID controller cache store READ & WRITE "hot data" significantly enhancing storage performance (SSD can be mirrored for data protection)

2 DRAM embedded on controller enables spinning drives to reach optimal performance

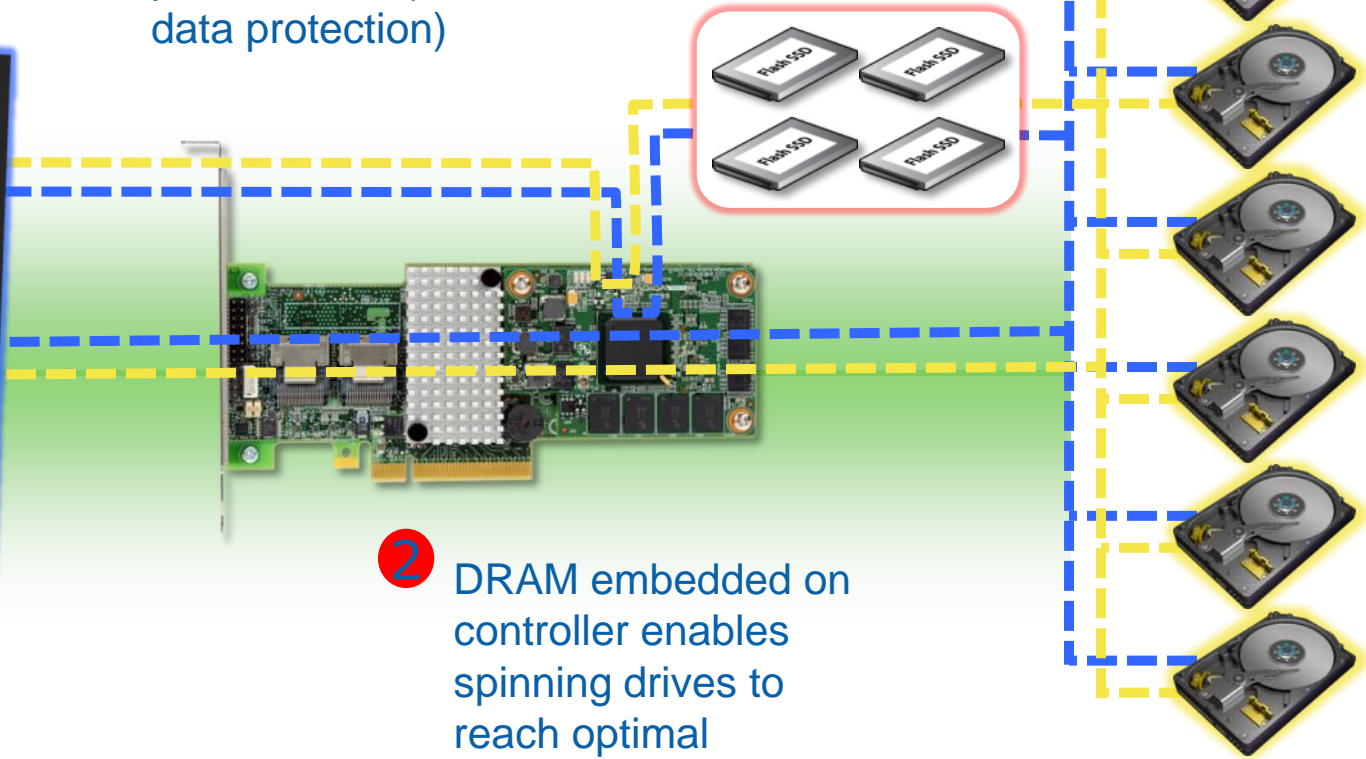

SSD benefits without a full array of SSD



Enabling SSD Cache 2.0

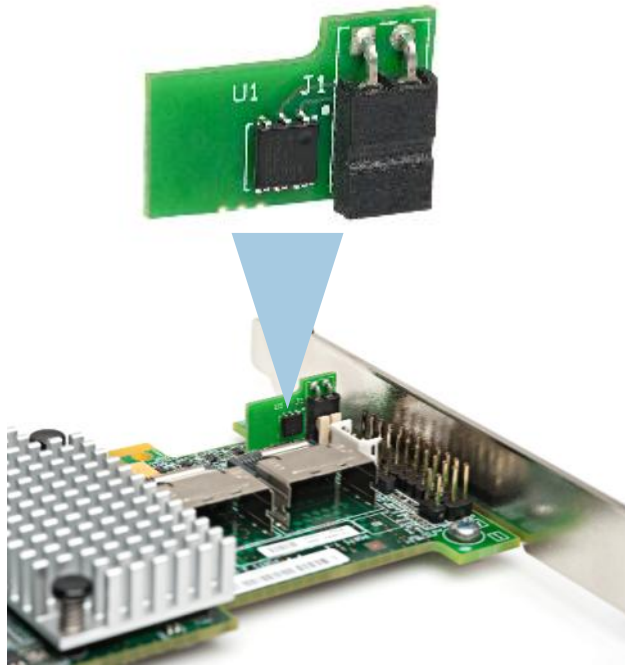

Ready to go in minutes:

1. Add order code **AXRPFKSSD** Premium Feature Key to Intel SAS-2 Mainstream or Scalable Performance RAID card
2. Connect SSD(s)
3. Configure SSD's as cache using Intel RAID Web Console

SSD Cache Benchmarks

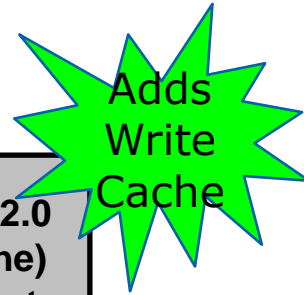

Benchmark**	SSD Cache 1.0 (Read Cache) Improvement	SSD Cache 2.0 (R + W Cache) Improvement
TPC-E (Microsoft SQL Server)	316%	1251%
Neoload (Web Server Simulation)	360%	533%
SysBench (MySQL Transactional Server)	84%	150%
Jetstress 2010 (Microsoft Exchange Server 2010)	29%	163%

** Benchmarks selected to simulate common servers in service. SSD Cache = 4 x Intel X25-E 32GB (Total of 128GB).

SSD Cache 2.0 Benefits Span All Server Applications



Intel® Integrated RAID

Complete line of RAID and SAS Modules

Horizontal in Rack

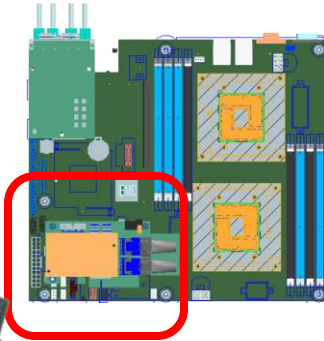

Features:

- Entry-level IOC-based (4 SKUs)
- Mainstream dual-core ROC-based w/ DDR3 (6 SKUs)

Form Factor:

- 1U capable SIO Module (5 SKUs)
- PCIe slot; low profile (5 SKUs)

Cache Protection:

- Long life Lithium Polymer BBU; or
- Maintenance Free Backup Up (NAND Flash and Supercap-based)

Other:

- Premium Features such as SSD Cache 2.0 optional
- Expand up to 32 ports with Intel® RAID Expander RES2CV360

Vertical (Std PCIe)
in Pedestal



www.intel.com/go/RAID



- **Benefits:**

- Using HW vs. SW RAID
- Performance vs. Competition

- **Products:**

- Portfolio Brochure
- Featured Downloads

- **Learn:**

- RAID 101
- RAID Web Console

- **Tech Insight:**

- Recipes
- Configuration Advice

Everything you need to quickly become an expert!

